

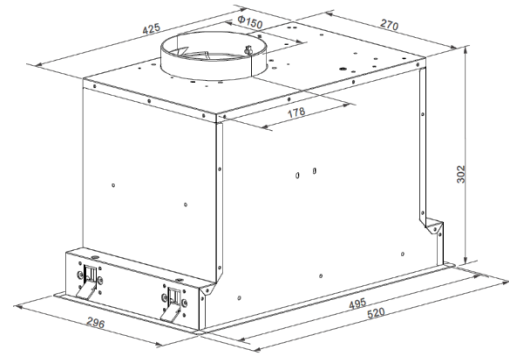

Dimension/Weight

Product Dimensions: 520(w) x 296(d) x 302(h) mm
 Carton Dimensions: 565(w) x 385(d) x 340(h) mm
 Net/Gross Weight: 9/11 kg
 Cut-Out Size: 500(w) x 275(d)



Technical Details

Style

Rangehood Type: Under Mount
 Rangehood Size: 52cm

Specifications

Max Airflow: 1000m³ / hr
 Power Levels: 3
 Filtration: 1 x Aluminium filter
 Lights: 2 x 1.5W LED
 Motor Power: 265W
 Voltage: 240v, 50Hz
 Installation Type: Hidden
 Ducted or Recirculated: Ducted only
 Come with Plug: Yes
 Warranty: 48 Months Parts & Labour

IEC 61951 Tested Air Flow		
Power Level	Air Flow (m ³ /hr)	Noise Level (dB)
1	189	45
2	576	58
3	709	69

Aesthetics

Finish: Stainless Steel
 Control Type: Electronic backlit buttons
 LED Display Colour: White

Key Features

- 1

High Performance
 Max motor performance of 1,000 m³/hr extraction rapidly removes steam, smoke, and cooking smells from your kitchen.
- 2

LED Lights
 2 LED lights efficiently illuminates the whole cooking area.
- 3

Stainless Steel Finish
 Stainless steel appliances are easy to clean, more durable and have increased longevity.

Customer Care

T: 09 415 6000
 W: omegaappliances.com.au
 W: omegaappliances.co.nz