

OPTIMO

Irreversible electromechanical gear motor for swing gates. External fitting.

PRODUCT CODE:

OPTIMO-2-24

LEAF:

Max 2.50m wide

MOTOR:

24V DC Intensive Use

DESCRIPTION:

Model equipped with mechanical stop for opening and closing.

Dimensions

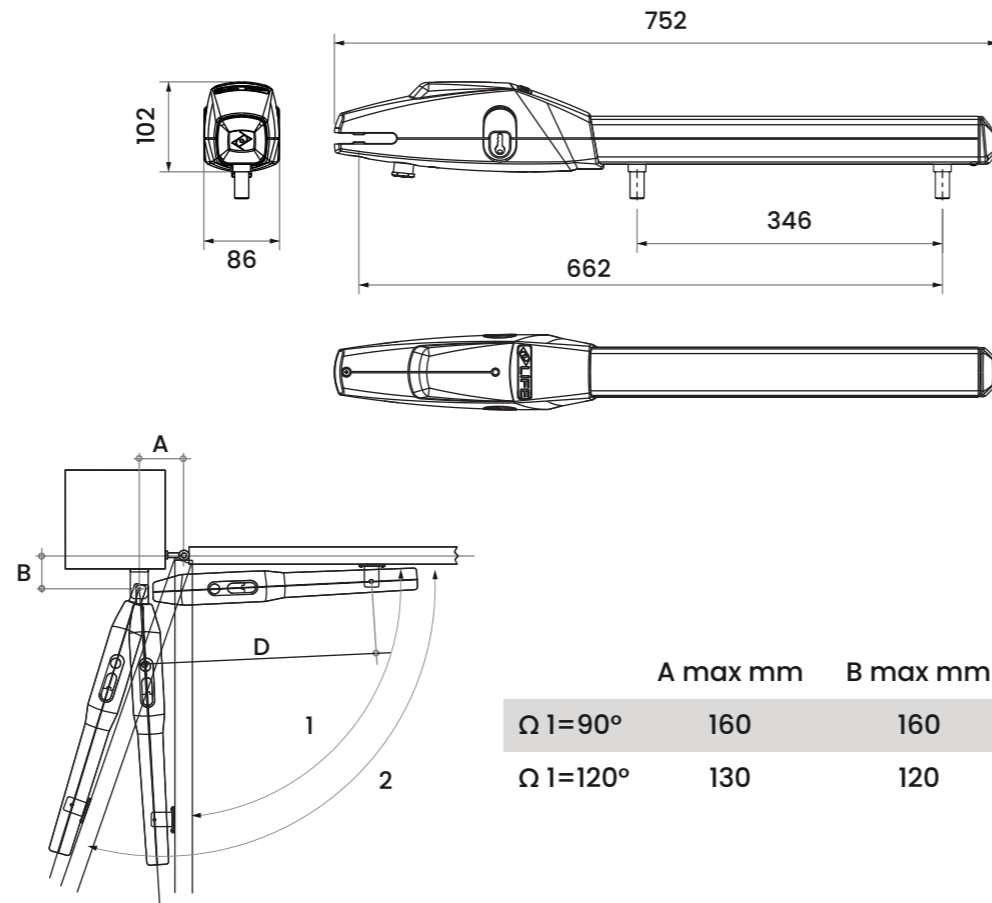

	A max mm	B max mm	D max mm
Ω 1=90°	160	160	640
Ω 1=120°	130	120	640

Technical Specifications

Max. gate leaf length (m)	2.50
Motor power supply (V)	24V d.c.
Power (W)	60
Thrust (N)	1500
Rod stroke (mm)	346
Operating T° (°C Min/Max)	- 20 + 70
Protection class (IP)	54
Work intermittence (%)	80
Time to cover 90° (s)	15

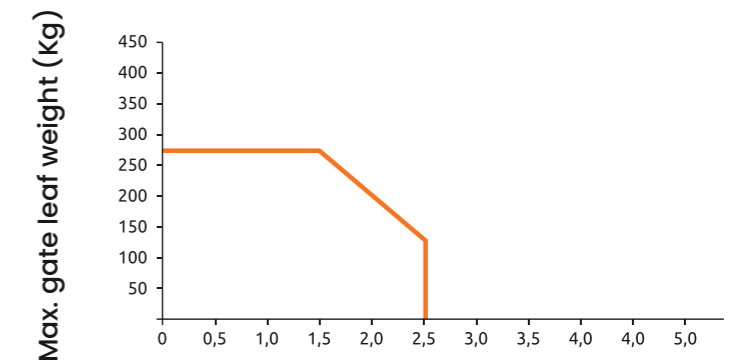

Electromechanical gearmotor for sliding gates, with control unit.

NB. In windy areas or when the gate has a particular structural shape, we advise reducing the limits on above weight/width.

