

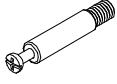





MODULAR WARDROBE 4 DRW 3 SHLF

SKU: 2031991/2031993

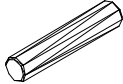
Hardware List

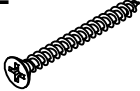
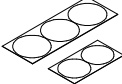
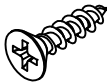
A  Cam Lock 50 Pcs	B  Klix Cam 50 Pcs	C  Dowel 48 Pcs	D  Shelf Support 12 Pcs	E  Screw # 5*65 2 Pcs	H  Hole Cap 52 Pcs	I  Screw # 4*16 40 Pcs	J  Drawer Slide 8 Pcs
--	---	--	--	--	--	---	--

REQUIRED ASSEMBLY TOOLS (Not included)

1. Phillips screwdriver-For installation of screws and Cam Lock and other accessories.
2. Tape measure-Measuring dimensions.
3. Hand electric drill-Used for making holes in cabinets or walls.
4. Level-Ensures that cabinets are kept level when installed.
5. Quick clamp-Make sure there are no gaps between cabinets when connecting two cabinets.

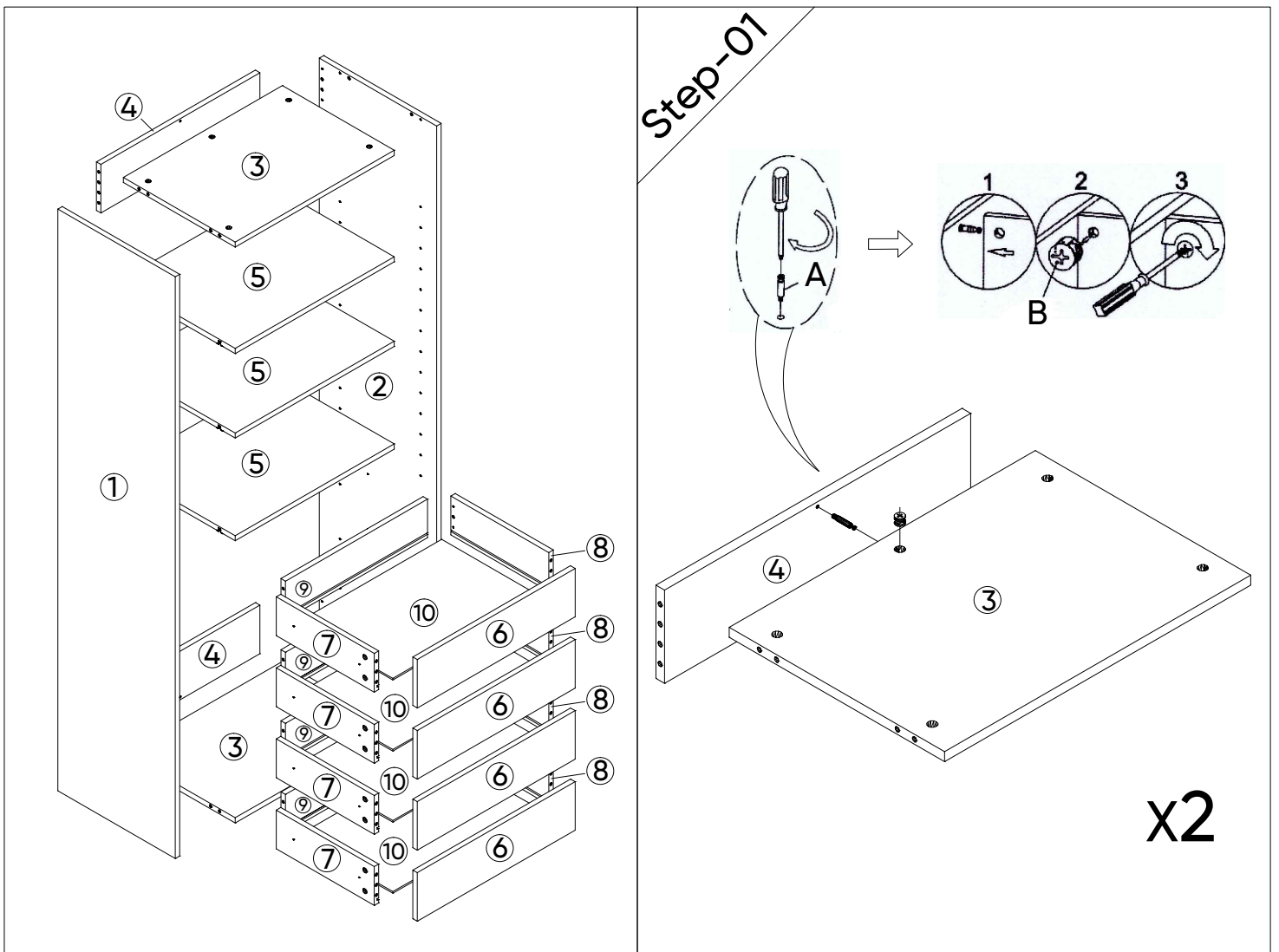

Step-02

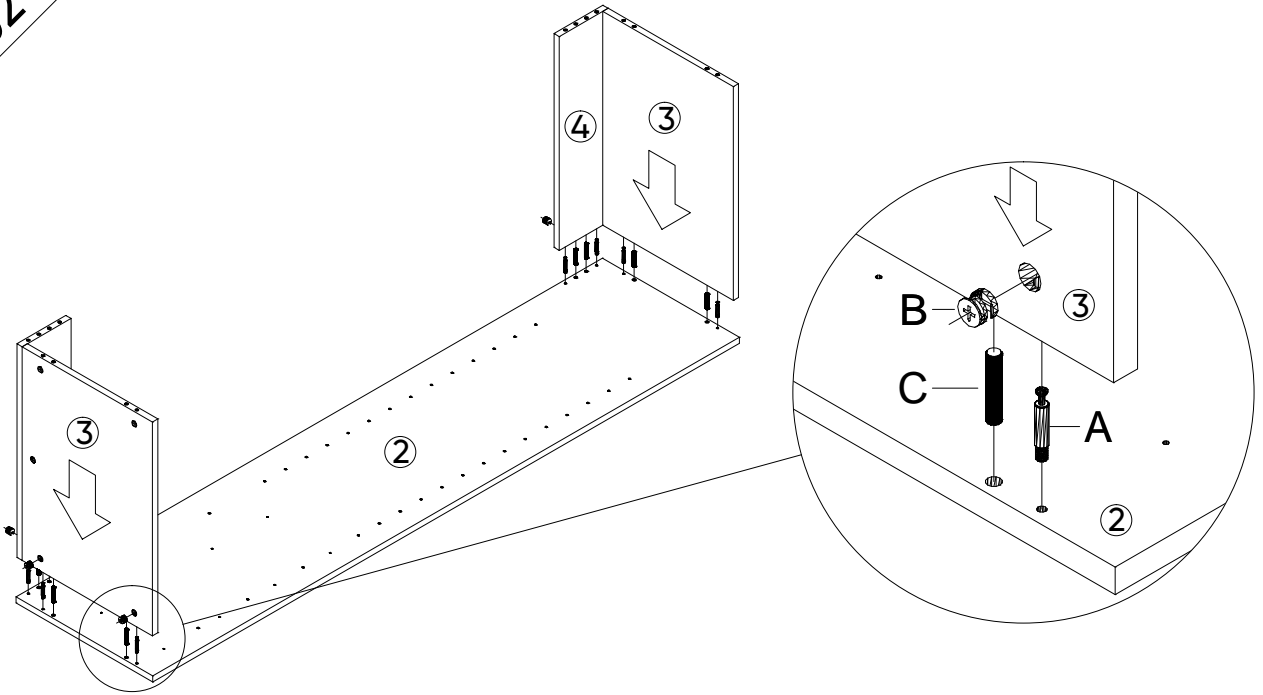

Step-03

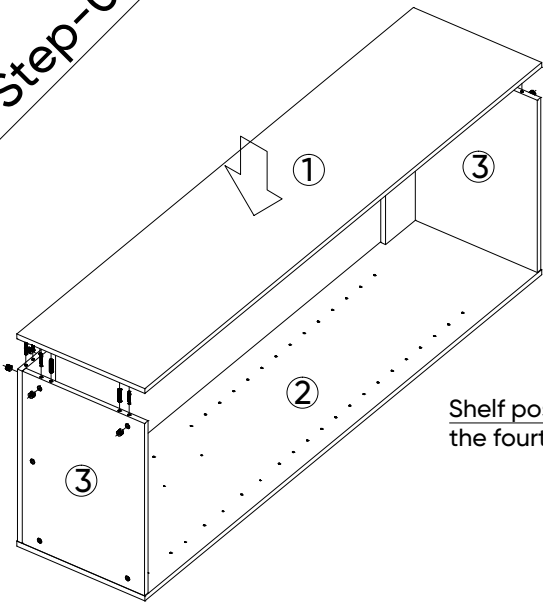

Step-04

Bottom shelf layout

Shelf position of the fourth drawer

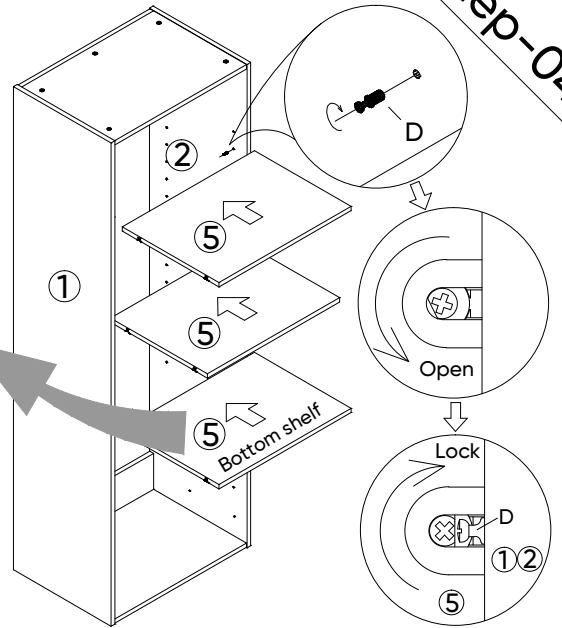
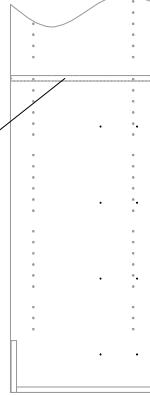

Make sure all the locks are opened before putting on the shelf.

Step-05

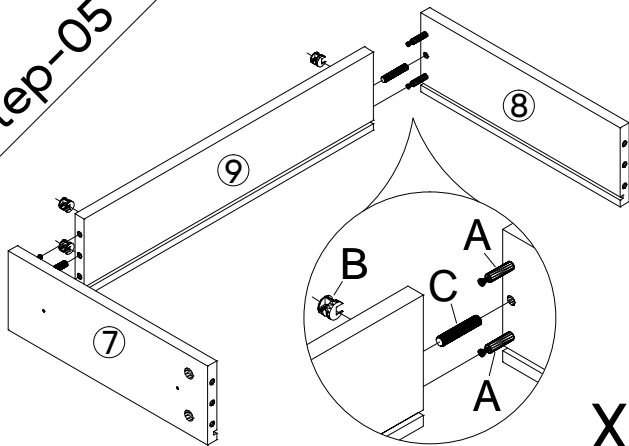

X4

Step-06

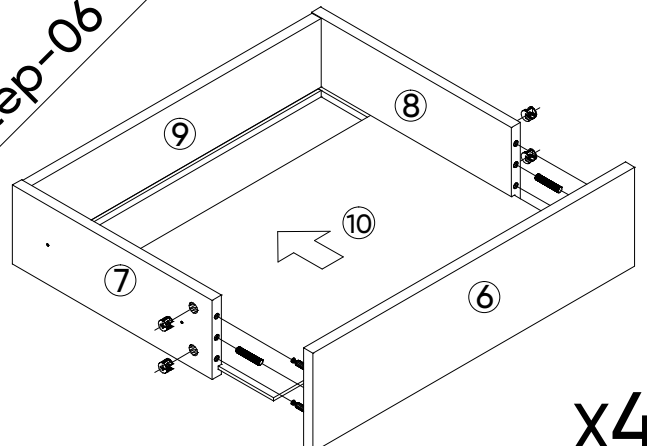

X4

Step-07

Do not protrude side panels.

Pay attention to:
The track of the drawer must be divided into two parts before installation.

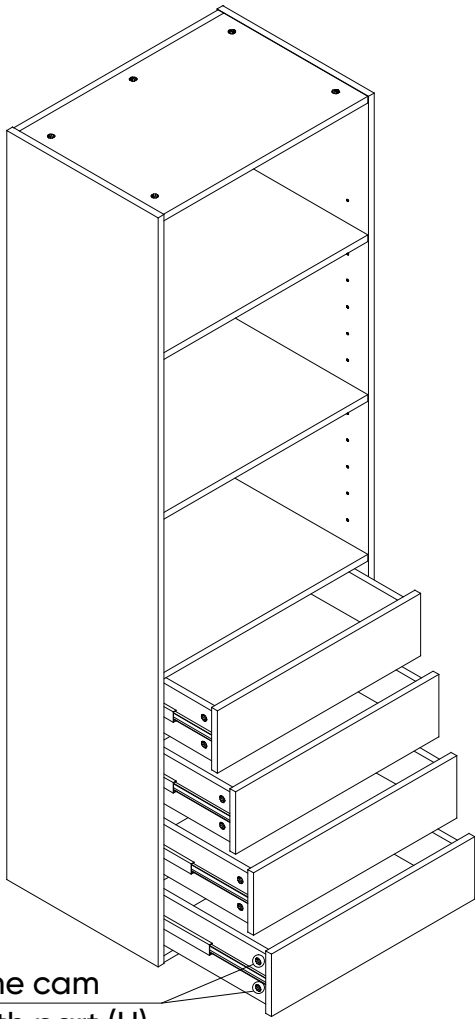
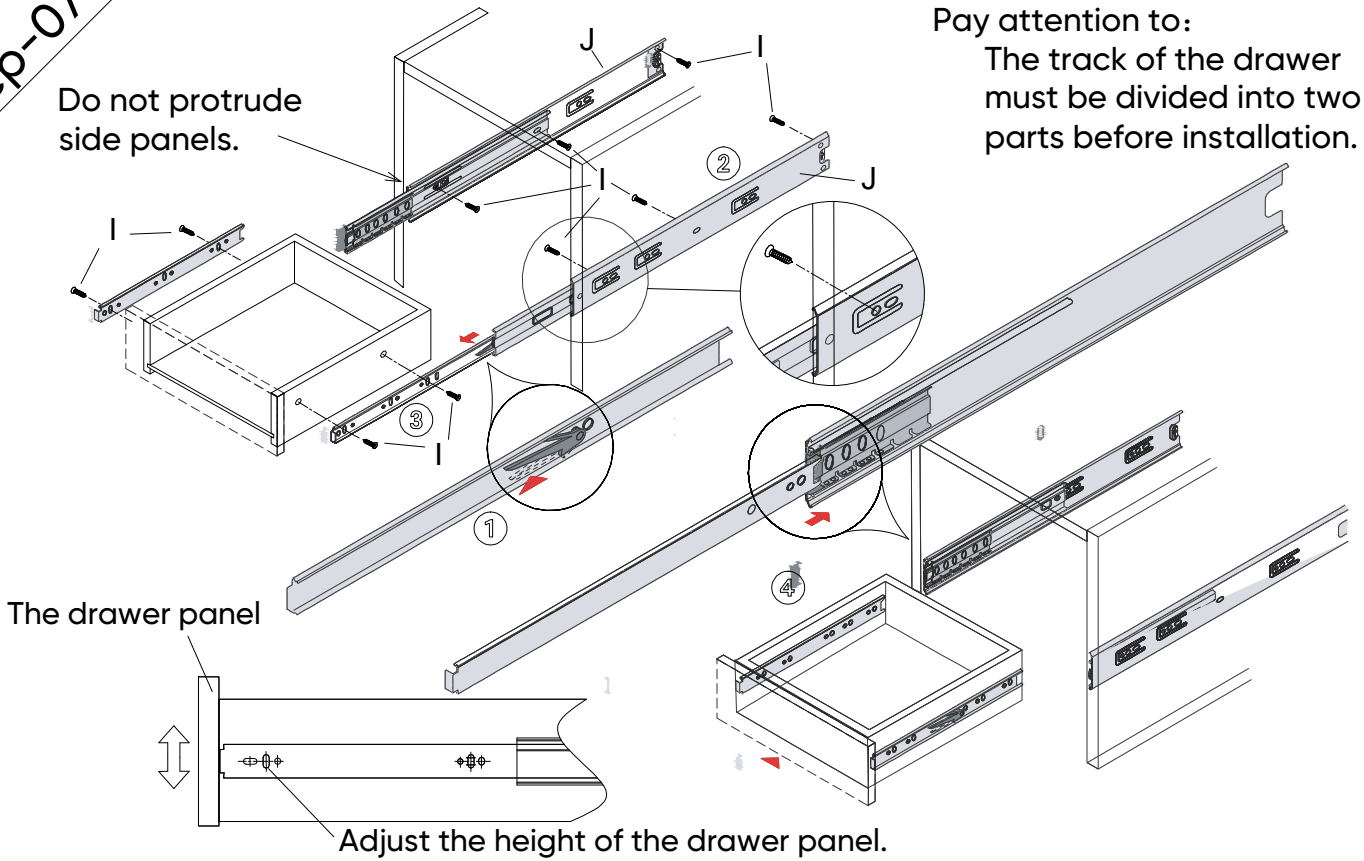

Cover the cam holes with part (H).

Finished

★ Please use E screw to fix the cabinet on the wall.

