

DEUS

Non-reversing electromechanical gear motor for sliding gates.
Above-ground installation.

PRODUCT CODE:

DEUS-4-24

GATE LEAF:

Max 400 Kg

MOTOR:

24V d.c.

DESCRIPTION:

Model equipped with double encoder and control unit (CT1 24VL)

Dimensions

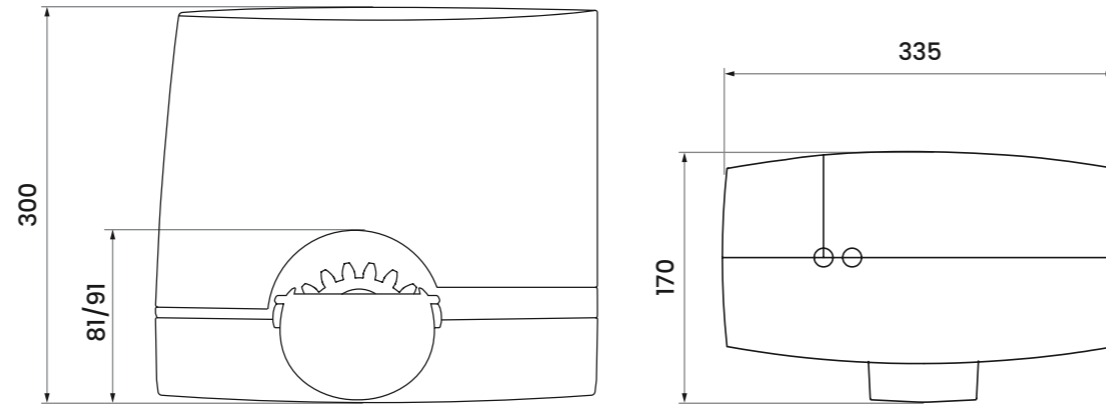

Technical Specifications

Max gate leaf weight (Kg)	400
Motor (V)	24V d.c.
Power rating (W)	120
Thrust (N)	300
Lubrication (type)	Permanent grease
Heat protection (°C)	140
Operating temperature (°C Min/Max)	- 20 +70
IP rate	55
Max speed (m/s)	0.23
Peak torque (Nm)	12
Continuous duty (min.)	20
Duty cycle (%)	80
Pinion height - h (mm)	91

Electromechanical gearmotor for sliding gates, with control unit.

